

REMOVE SHARP EDGES & BURRS		TOL MET AFTER SURFACE TREATMENT		
PT NO.	NO. OFF: 5	OPTICAL DEVICES AND SYSTEMS	DRN	HG
MATL: STAINLESS STEEL			CHD	SS
SIZE:		CSIR-CSIO CHANDIGARH	PASD	VK
SURFACE TREATMENT			APPD	RCMA
REF:		MECHANICAL COMP.	SCALE 5:1	
			SH 1 OF 1 SHS A3	

REV	CHANGE MADE	DATE	BY	APPD	GEN TOL IS: 2102(Part-1)-1980						
					ABOVE	0.5	3	6	30	120	315
					UP TO	3	6	30	120	315	1000
					TOL ±	0.05	0.05	0.1	0.15	0.2	0.3

263203001-004

DRG.NO.

IF IN DOUBT ASK

ISSUE REVISION CLASS

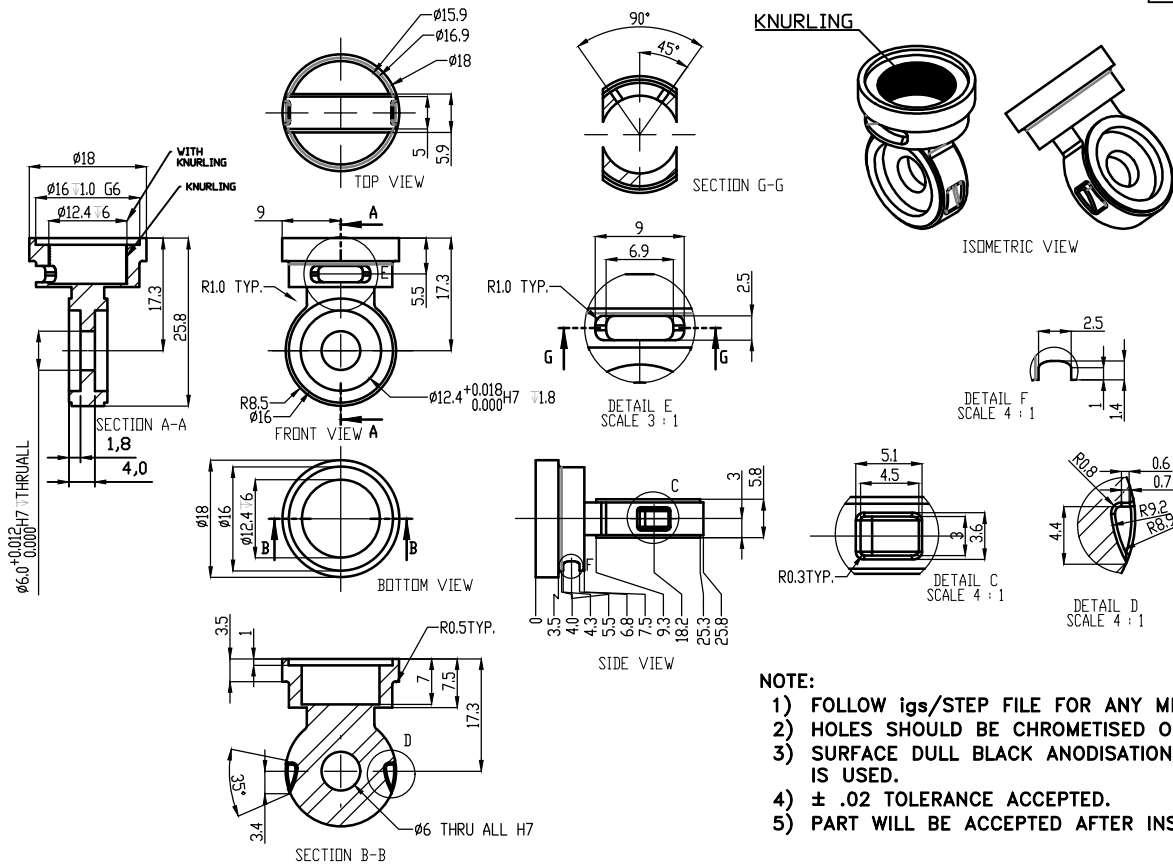

NOTE:

- 1) FOLLOW igs/STEP FILE FOR ANY MISSING DIMENSION.
- 2) HOLES SHOULD BE CHROMETISED ONLY.
- 3) SURFACE DULL BLACK ANODISATION WHEN AL ALLOY IS USED.
- 4) $\pm .02$ TOLERANCE ACCEPTED.
- 5) PART WILL BE ACCEPTED AFTER INSPECTION.

CRITICAL FOR INSTALLATION PURPOSE

ISSUE	'A'				
DATE	00.00.0000				
REF.NO.					
DRN.	name				
CHD.	name				
MATL.	name				
DQAC	name				
APPD.	name				

UNLESS OTHERWISE STATED

1. DIMENSIONS ARE IN mm.
2. LIMIT ± 0.2 ; $\pm 30'$
3. SURFACE FINISH $\frac{16}{\sqrt{}}$ (CLA)
4. ROUND OFF SHARP EDGES
5. METRIC THREADS AS PER IS:4218
6. FINISHED SIZES SHOWN (AFTER PLATING)
7. DO NOT SCALE

MATERIAL	SPEC.	HEAT TRT.	SPEC.	PROTECTIVE TRT.	SPEC.
AL6061T6	---	---	---	---	---
	EST.WT.(g)	JOINT CAP LAP LIGHT			
	4.5 \pm 1.0				
SCALE	5 : 1	SHEET	01 OF 01	ASSY.NO.	5.1
	Aerospace Systems Equipment Research and Design Centre H A L, LUCKNOW			DRG.NO.	263203001-004

263203008-004

DRG.NO.

IF IN DOUBT ASK

ISSUE REVISION CLASS

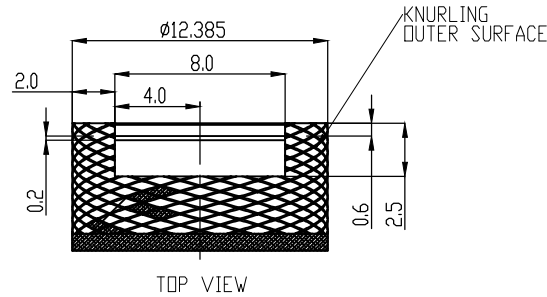

TOP VIEW

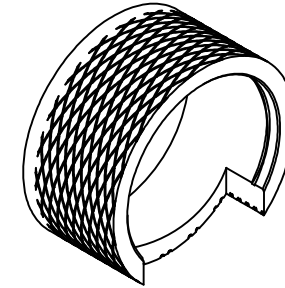

ISOMETRIC VIEW

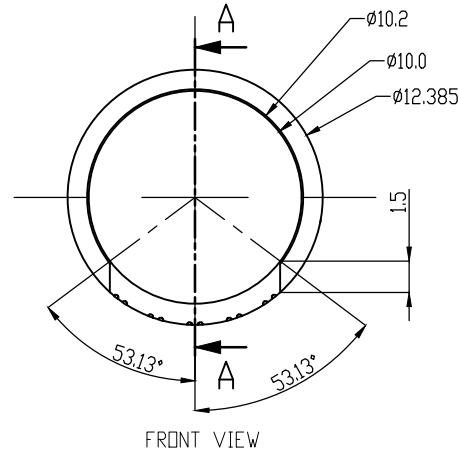

FRONT VIEW

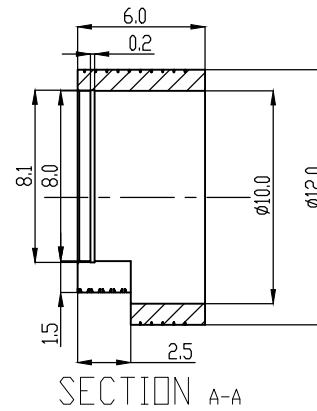

SECTION A-A

NOTE:

- 1) FOLLOW igs/STEP FILE FOR ANY MISSING DIMENSION.
- 2) $\pm .02$ TOLERANCE ACCEPTED.
- 3) PART WILL BE ACCEPTED AFTER INSPECTION.
- 4) DRAWING IS IN THIRD ANGLE PROJECTION.

*(CRITICAL FOR INSTALLATION PURPOSE)

ISSUE	'A'				
DATE					
REF.NO.					
DRN.	name				
CHD.	name				
MATL.	name				
DQAC	name				
APPD.	name				

UNLESS OTHERWISE STATED

1. DIMENSIONS ARE IN mm.
2. LIMIT ± 0.2 ; $\pm 30'$
3. SURFACE FINISH $\sqrt{16}$ (CLA)
4. ROUND OFF SHARP EDGES
5. METRIC THREADS AS PER IS:4218
6. FINISHED SIZES SHOWN (AFTER PLATING)
7. DO NOT SCALE

MATERIAL	SPEC.	HEAT TRT.	SPEC.	PROTECTIVE TRT.	SPEC.
STAINLESS STEEL	---	---	---	---	---
SS 304					

	EST.WT.(g) 2.0 \pm 0.5	JOINT CAP RING LAP LIGHT
--	-----------------------------	-----------------------------

SCALE 5 : 1	SHEET 01 OF 01	ASSY.NO. 5.4
-------------	----------------	--------------

	Aerospace Systems Equipment Research and Design Centre H A L, LUCKNOW	DRG.NO. 263203008-004
--	---	--------------------------